

MOUNTING INSTRUCTIONS

1 - **SCREW THE RAIL** on the rifle, paying attention at the correct orientation (caption FRONT towards the barrel)

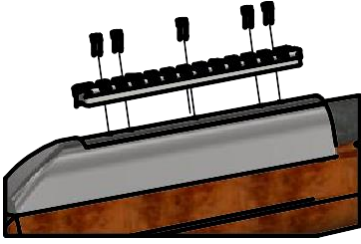

ATTENTION: - for the correct tightening use the threadlocker with MAX force 3 Nm.

2 - **ASSEMBLY OF THE MOUNT**

- a) Open the lever of the mount
- b) Put the mount on the rail inserting the recoil stop into one of the specific slots.



3 - **CLOSE THE LEVER**

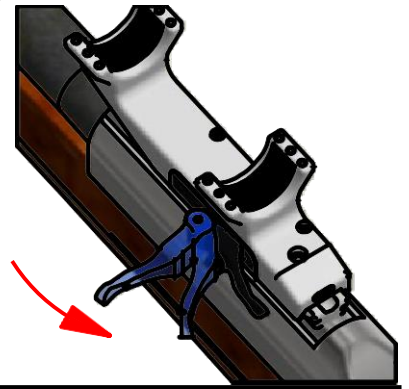

EXCLUSIVELY IN CASE OF NEED

ADJUST THE TIGHTENING STRENGTH OF THE LEVER

- A) carefully loosen the inclined fixing grub screw using a 2.5 mm hexagonal wrench.
- B) tighten the side screw to the grub screw at a force of 1.8 - 2 Nm with a 4 mm wrench.
- C) carefully tighten the inclined fixing grub screw using a 2.5 mm hexagonal wrench.
- D) make sure that the Allen keys are fully inserted into the hexagonal seats when tightening.

a) - c)

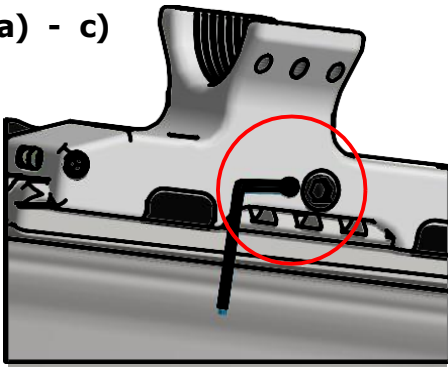

b)

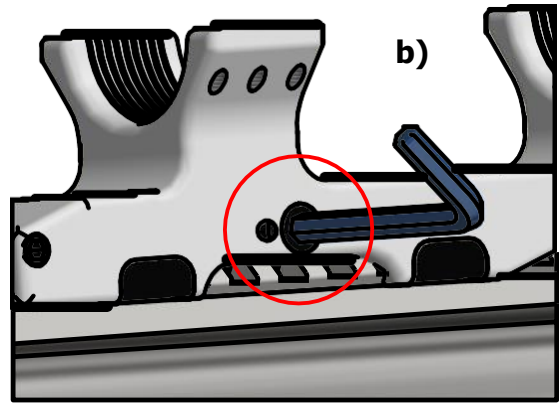

4- **POSITION THE SCOPE,** SCREW THE TOP RINGS with the provided screws at their specific bases.

ATTENTION: - for the correct tightening use the threadlocker with MAX force 2 Nm.

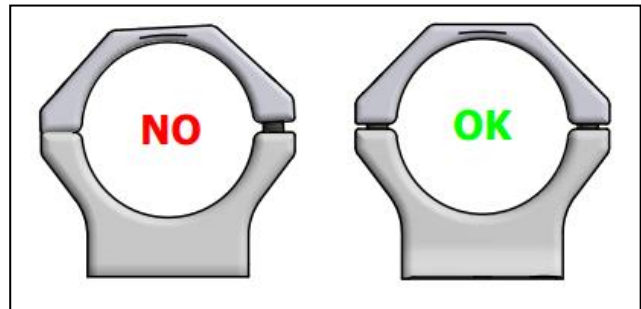

ATTENTION

- 4a - Make a parallel tightening of the upper rings, to guarantee a correct and efficient locking of the scope
- 4b - The tightening of the screws must be done in cross mode, in this way it guarantees an efficient locking of the scope
- 4c - Make sure that the Torx keys are fully inserted into the seats when tightening

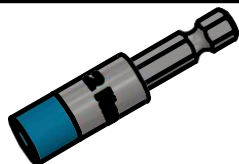

ON REQUEST CAN BE GIVE A TORQUE WRENCH AT 2 Nm APPOSITE FOR LEND ATTENTION AT EVERY TIGHTENING

THE MANUFACTURER IS RELIEVED FROM ANY LIABILITY FOR USE NOT IN CONFORMITY WITH THE PRODUCT ASSEMBLY INSTRUCTIONS, FOR TAMPERING, FOR INCORRECT ASSEMBLIES, MODIFICATIONS AND REPLACEMENTS NOT PERFORMED BY THE COMPANY'S STAFF. IMPROPER USE OF THE PRODUCT IS FORBIDDEN